

| | | |
|-----------|------------------------------|----|
| DE | Montageanleitung | 2 |
| FR | Instructions de montage | 2 |
| EN | assembly instructions | 3 |
| IT | Istruzioni per Installazione | 3 |
| ES | Instrucciones de montaje | 4 |
| NL | Handleiding | 4 |
| DK | Monteringsvejledning | 5 |
| PT | Manual de Instalação | 5 |
| PL | Instrukcja montażu | 6 |
| CS | Montážní návod | 6 |
| SK | Montážny návod | 7 |
| ZH | 组装说明 | 7 |
| RU | Инструкция по монтажу | 8 |
| HU | Szerelési útmutató | 8 |
| FI | Asennusohje | 9 |
| SV | Monteringsanvisning | 9 |
| LT | Montavimo instrukcijos | 10 |
| HR | Uputstva za instalaciju | 10 |
| TR | Montaj kılavuzu | 11 |
| RO | Instrucțiuni de montare | 11 |
| EL | Οδηγία συναρμολόγησης | 12 |
| SL | Navodila za montažo | 12 |
| ET | Paigaldusjuhend | 13 |
| LV | Montāžas instrukcija | 13 |
| SR | Uputstvo za montažu | 14 |
| NO | Montasjeveiledning | 14 |
| BG | Ръководство за монтаж | 15 |
| SQ | Udhëzime rreth montimit | 15 |
| AR | تعليمات التجميع | 16 |

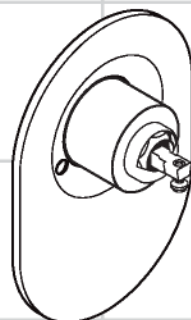

96384XXX

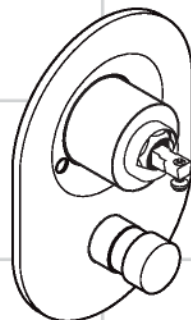

96385XXX

97332XXX

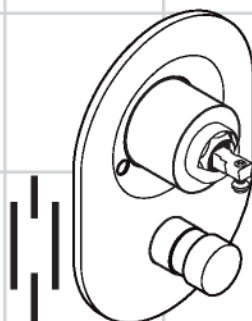

97111XXX



Sicherheitshinweise

- ⚠ Bei der Montage müssen zur Vermeidung von Quetsch- und Schnittverletzungen Handschuhe getragen werden.

Montagehinweise

- Vor der Montage muss das Produkt auf Transportschäden untersucht werden. Nach dem Einbau werden keine Transport- oder Oberflächenschäden anerkannt.
- Die Leitungen und die Armatur müssen nach den gültigen Normen montiert, gespült und geprüft werden.
- Die in den Ländern jeweils gültigen Installationsrichtlinien sind einzuhalten.

Symbolerklärung



Kein essigsäurehaltiges Silikon verwenden!



Maße (siehe Seite 19)



Serviceteile (siehe Seite 17)



Reinigung

siehe beiliegende Broschüre.



Justierung

Einhandmischer mit Warmwasserbegrenzung, Justierung siehe Seite 24. In Verbindung mit Durchlauferhitzern ist eine Warmwassersperre nicht zu empfehlen.

Consignes de sécurité

- ⚠ Lors du montage, porter des gants de protection pour éviter toute blessure par écrasement ou coupure.

Instructions pour le montage

- Avant son montage, s'assurer que le produit n'a subi aucun dommage pendant le transport. Après le montage, tout dommage de transport ou de surface ne pourra pas être reconnu.
- Les conduites et la robinetterie doivent être montés, rincés et contrôlés selon les normes en vigueur.
- Les directives d'installation en vigueur dans le pays concerné doivent être respectées.

Description du symbole



Ne pas utiliser de silicone contenant de l'acide acétique!



Dimensions (voir page 19)



Pièces détachées (voir pages 17)



Nettoyage

voir la brochure ci-jointe.



Étalonnage

Mitigeur avec limitation de la température: voir la page 24 pour le réglage. Une limitation de la température n'est pas recommandée quand le mitigeur est alimenté par un chauffe-eau instantané.

Montage siehe Seite 20



Montage voir page 20



Safety Notes

-  Gloves should be worn during installation to prevent crushing and cutting injuries.

Installation Instructions

- Prior to installation, inspect the product for transport damages. After it has been installed, no transport or surface damage will be honoured.
- The pipes and the fixture must be installed, flushed and tested as per the applicable standards.
- The plumbing codes applicable in the respective countries must be observed.

Symbol description



Do not use silicone containing acetic acid!



Dimensions (see page 19)



Spare parts (see page 17)



Cleaning

see enclosed brochure.



Adjustment

To adjust the hot water limiter on single lever mixers, please see page 24. Using a hot water limiter in connection with a continuous flow water heater is not recommended.

Indicazioni sulla sicurezza

-  Durante il montaggio, per evitare ferite da schiacciamento e da taglio bisogna indossare guanti protettivi.

Istruzioni per il montaggio

- Prima del montaggio è necessario controllare che non ci siano stati danni durante il trasporto. Una volta eseguito il montaggio, non verranno riconosciuti eventuali danni di trasporto o delle superfici.
- Montare, lavare e controllare tubature e rubinetteria rispettando le norme correnti.
- Vanno rispettate le direttive di installazione nazionali vigenti nel rispettivo paese.

Descrizione simbolo



Non utilizzare silicone contenente acido acetico!



Ingombri (vedi pagg. 19)



Parti di ricambio (vedi pagg. 17)



Pulitura

vedi il prospetto accluso.



Taratura

Per la regolazione del limitatore di erogazione di acqua calda dei miscelatori monocomando, vedi Pagina 24. Un limitatore di erogazione di acqua calda in combinazione con le caldaie istantanee non è consigliabile.

Assembly see page 20



Montaggio vedi pagg. 20



Indicaciones de seguridad

- ⚠ Durante el montaje deben utilizarse guantes para evitar heridas por aplastamiento o corte.

Indicaciones para el montaje

- Antes del montaje se debe examinarse el producto contra daños de transporte. Después de la instalación so se reconoce ningún daño de transporte o de superficie.
- Los conductos y la grifería deben montarse, lavarse y comprobarse según las normas vigentes.
- Es obligatorio el cumplimiento de las directrices de instalación vigentes en el país respectivo.

Descripción de símbolos



No utilizar silicona que contiene ácido acético!



Dimensiones (ver página 19)



Repuestos (ver página 17)



Limpiar

ver el folleto adjunto.



Ajuste

Uso como mezclador monomando con limitación del caudal de agua caliente: ver ajuste en pagina 24. En combinación con calentadores instantáneos no es recomendable limitar el caudal de agua caliente.



Veiligheidsinstructies

- ⚠ Bij de montage moeten ter voorkoming van knel- en snijwonden handschoenen worden gedragen.

Montage-instructies

- Vóór de montage moet het product gecontroleerd worden op transportschade. Na de inbouw wordt geen transport- of oppervlakteschade meer aanvaard.
- De leidingen en armaturen moeten gemonteerd, gespoeld en gecontroleerd worden volgens de geldige normen.
- De in de overeenkomstige landen geldende installatie-richtlijnen moeten nageleefd worden.

Symboolbeschrijving



Gebruik geen zuurhoudende silicone!



Maten (zie blz. 19)



Service onderdelen (zie blz. 17)



Reinigen

zie bijgevoegde brochure.



Instellen

Eéngreepsmengkranen met warmwaterbegrenzing, instelling zie blz. 24. In combinatie met geisers wordt een warmwaterbegrenzing niet aanbevolen.

Montaje ver página 20



Montage zie blz. 20



Sikkerhedsanvisninger

- ⚠ Ved monteringen skal der bruges handsker for at undgå kvæstelser og snitsår.

Monteringsanvisninger

- Før monteringen skal produktet kontrolleres for transportskader. Efter monteringen godkendes transportskader eller skader på overfladen ikke længere.
- Ledningerne og armaturerne skal monteres, skylles og kontrolleres iht. de gældende standarder.
- Installationsbestemmelserne, der gælder i det enkelte land, skal overholdes.

Symbolbeskrivelse



Der må ikke benyttes eddikesyreholdig silikone!



Målene (se s. 19)



Reserve dele (se s. 17)



Rengøring

se venligst den vedlagte brochure.



Forindstilling

Etgrebsarmaturer med varmtvandsbegrænsning, justering se side 24. I forbindelse med gennemstrømningsvandvarmer anbefales en varmtvandsbegrænsning ikke.

Avisos de segurança

- ⚠ Durante a montagem devem ser utilizadas luvas de protecção, de modo a evitar ferimentos resultantes de entalamentos e de cortes.

Avisos de montagem

- Antes da montagem deve-se controlar o produto relativamente a danos de transporte. Após a montagem não são aceites quaisquer danos de transporte ou de superfície.
- As tubagens e a torneira têm que ser montadas, enxaguadas e verificadas de acordo com as normas em vigor.
- A prescrições de instalação válidas nos respetivos países devem ser respeitadas.

Descrição do símbolo



Não utilizar silicone que contenha ácido acético!



Medidas (ver página 19)



Peças de substituição (ver página 17)



Limpeza

consultar a seguinte brochura.



Afinação

Misturadora monocomando equipada com limitador de temperatura (vide pàg. 24). Em combinação com caldeira ou esquentador instantâneo o limitador de água quente não é recomendado.

Montering se s. 20



Montagem ver página 20



Wskazówki bezpieczeństwa

-  Aby uniknąć zranień, takich jak zgniecenia czy przecięcia, podczas montażu należy nosić rękawice.

Wskazówki montażowe

- Przed montażem należy skontrolować produkt pod kątem szkód transportowych. Po montażu nie widać żadnych szkód transportowych ani szkód na powierzchni.
- Przewody i armatura muszą być montowane, płukane i kontrolowane według obowiązujących norm.
- Należy przestrzegać wytycznych instalacyjnych obowiązujących w danym kraju.

Opis symbolu



Nie stosować silikonów zawierających kwas octowy!



Wymiary (patrz strona 19)



Części serwisowe (patrz strona 17)



Czyszczenie

patrz dołączona broszura.



Ustawianie

Mieszacz jednouchwytowy z ogranicznikiem temperatury wody, ustawianie, patrz str. 24. Używanie ogranicznika temperatury wody w połączeniu z przepływowym podgrzewaczem wody nie jest zalecane.

Bezpečnostní pokyny

-  Pro zabránění řezným zraněním a pohmožděním je nutné při montáži nosit rukavice.

Pokyny k montáži

- Před montáží je třeba produkt zkontrolovat, zda nebyl při transportu poškozen. Po zabudování nebudou uznány žádné škody způsobené transportem nebo poškození povrchu.
- Vedení a armatura musí být namontovány, propláchnuty a otestovány podle platných norem.
- Je třeba dodržovat montážní pravidla platné v dané zemi.

Popis symbolů



Nepoužívat silikon s obsahem kyseliny octové!



Rozměry (viz strana 19)



Servisní díly (viz strana 17)



Čištění

viz přiložená brožura.



Nastavení

Páková baterie s omezením horké vody, seřízení viz. str. 24. Ve spojení s průtokovými ohřívači nedoporučujeme používat uzavřené teplé vody.

Montaż patrz strona 20



Montáž viz strana 20

**! Bezpečnostné pokyny**

- △ Pri montáži musíte nosiť rukavice, aby ste predišli pomliaždeninám a rezným poraneniam.

Pokyny pre montáž

- Pred montážou musíte produkt skontrolovať, či nebol počas transportu poškodený. Po zabudovaní nebudú uznané žiadne škody spôsobené transportom alebo poškodenia povrchu.
- Ledningarna och blandaren måste monteras, spolás igenom och kontrolleras enligt de gällande normerna.
- Je potrebné dodržiavať smernice o inštalácii, ktoré sú práve teraz platné v krajinách.

Popis symbolov

Nepoužívať silikón s obsahom kyseliny octovej!



Rozmery (viď strana 19)



Servisné diely (viď strana 17)



Čistenie

nájdete v priloženej brožúre.



Nastavenie

Páková batéria s obmedzením teplej vody, nastavenie viď.str. 24. V spojení s prietokovými ohrievačmi sa uzáver teplej vody neodporúča.

! 安全技巧

- △ 装配时为避免挤压和切割受伤，必须戴上手套。

安装提示

- 安装前必须检查产品是否受到运输损害。安装后将不认可运输损害或表面损伤。
- 管道和阀门必须根据通用标准进行安装、冲洗和检查。
- 请遵守当地国家现行的安装规定。

符号说明

请勿使用含有乙酸的硅！



大小(参见第 19 页)



备用零件(参见第 17 页)



清洗

附有小手册



调节

带有热水控制器的单手柄龙头的调节方法，参见第 24 页。如果与即热式热水器一起使用，则不建议使用止热水装置。

Montáž viď strana 20



安装 参见第 20 页



Указания по технике безопасности

- Во время монтажа следует надеть перчатки во избежание прищемления и порезов.

Указания по монтажу

- Перед монтажом следует проверить изделие на предмет повреждений при перевозке. После монтажа претензии о возмещении ущерба за повреждения при перевозке или повреждения поверхностей не принимаются.
- Трубы и арматура должны быть установлены, промыты и проверены в соответствии с действующими нормами.
- Необходимо соблюдать требования по монтажу, действующие в соответствующих странах.

Описание символов



Не применяйте силикон, содержащий уксусную кислоту.



Размеры (см. стр. 19)



Комплект (см. стр. 17)



Очистка

см прилагаемая брошюра



Подгонка

Однорычажный смеситель имеет ограничитель расхода горячей воды (см. Стр. 24: юстировка). В комбинации с проточными нагревателями не рекомендуется установка блокировка горячей воды!



Biztonsági utasítások

- A szerelésnél a zúzódások és vágási sérülések elkerülése érdekében kesztyűt kell viselni.

Szerelési utasítások

- A szerelés előtt ellenőrizni kell, hogy a terméknek nincs-e szállítási sérülése. Beépítés után a szállítási- vagy felületi sérüléseket nem ismerik el.
- A vezetékeket és a csaptelepet az érvényes szabványoknak megfelelően kell felszerelni, öblíteni és ellenőrizni
- Az egyes országokban érvényes installációs irányelveket be kell tartani.

Szimbólumok leírása



Ne használjon ecetsavtartalmú szilikon!



Méretet (lásd a 19. oldalon)



Tartozékok (lásd a 17. oldalon)



Tisztítás

lásd a mellékelt brosúrát.



Beállítás

Az egykaros, melegvíz-korlátozóval ellátott keverő csaptelep beállítását lásd a 24. oldalon. Az átfolyó rendszerű vízmelegítőknél nem ajánlott a melegvíz-korlátozó.

Монтаж см. стр. 20



Szerelés lásd a 20. oldalon



Turvallisuusohjeet

-  Asennuksessa on käytettävä käsiineitä puristumien ja viillojen aiheuttamien tapaturmien estämiseksi.

Säkerhetsanvisningar

-  Handskar ska bäras under monteringsarbetet så att man kan undvika kläm- och skärskadorgen werden.

Asennusohjeet

- Ennen asennusta on tarkastettava tuotteen mahdolliset kuljetusvahingot. Asennuksen jälkeen kuljetus- ja pintavaurioita ei hyväksytä.
- Putket ja hana on asennettava, huuhdeltava ja tarkastettava voimassa olevien standardien mukaisesti.
- Jokaisessa maassa on noudatettava siellä päteviä asennusohjeita.

Monteringsanvisningar

- Det måste undersökas om produkten har transportskador innan den monteras. Efter monteringen accepteras inga transport- eller ytskiktsskador.
- Ledningarna och blandaren måste monteras, spolas igenom och kontrolleras enligt de gällande normerna.
- De installationsriktlinjer som gäller i länderna ska följas.

Merkin kuvaus



Älä käytä etikahappopitoista silikoniala



Mitat (katso sivu 19)



Varaosat (katso sivu 17)



Puhdistus

katso oheinen esite



Säätö

Yksivipuinen sekoittaja lämpimän veden rajoituksella, katso säätö sivulta 24. Lämpimän veden rajoitusta ei suositella läpivirtauskuumentimen yhteydessä.

Symbolförklaring



Använd inte silikon som innehåller ättiksyra!



Måtten (se sidan 19)



Reservdelar (se sidan 17)



Rengöring

se den medföljande broschyren



Justering

Enhandsblandare med varmvattenreglering, justering se sidan 24. Tillsammans med varmvattenberedare rekommenderas inte en varmvattenreglering.

Asennus katso sivu 20



Montering se sidan 20



Saugumo technikos nurodymai

- ⚠️ Apsaugai nuo užspaudimo ir įsijovimo montavimo metu mūvėkite pirštines.



Sigurnosne upute

- ⚠️ Prilikom montaže se radi sprječavanja prignječanja i posjekotina moraju nositi rukavice.

Montavimo instrukcija

- Prieš montuojant būtina patikrinti, ar gaminys nebuvo pažeistas transportavimo metu. Sumontavus pretenzijos dėl transportavimo ir paviršiaus pažeidimų nepriimamos.
- Vamzdžiai ir sujungimai turi būti montuojami, plaunami ir tikrinami pagal galiojančias normas.
- Laikykitės atitinkamoje šalyje galiojančių direktyvų dėl įrengimo.

Simbolio aprašymas



Nenaudokite silikono, kurio sudėtyje yra acto rūgšties!



Išmatavimai (žr. psl. 19)



Atsarginės dalys (žr. psl. 17)



Valymas

žr. pridedamoje brošiūroje.



Reguliavimas

Vienos rankenėlės maišytuvus turi karšto vandens ribotuvą (nustatymą žr. psl. 24). Naudojant momentinį šildiklį karšto vandens ribotuvus nerekomenduojamas.

Upute za montažu

- Prije montaže mora se provjeriti je li proizvod oštećen prilikom transporta. Nakon ugradnje se ne priznaju nikakve reklamacije koje se odnose na površinska i transportna oštećenja.
- Cijevi i armatura moraju biti postavljeni, isprani i testirani prema važećim normama.
- Obvezno se moraju uvažiti propisi o instalacijama koji vrijede u dotičnoj zemlji.

Opis simbola



Nemojte koristiti silikon koji sadrži octenu kiselinu!



Mjere (pogledaj stranicu 19)



Rezervni djelovi (pogledaj stranicu 17)



Čišćenje

se u priloženoj brošuri.



Regulacija

Za namještanje jednoručnih miješalica s limiterom tople vode vidi str. 24. U kombinaciji s protočnim boilerima nije preporučljiva primjena sustava za blokiranje dotoka tople vode.

Montavimas žr. psl. 20



Sastavljanje pogledaj stranicu 20



! Güvenlik uyarıları

- ! Montaj esnasında ezilme ve kesilme gibi yaralanmaları önlemek için eldiven kullanılmalıdır.

! Instrucțiuni de siguranță

- ! La montare utilizați mănuși pentru evitarea contuziunilor și tăierii mâinilor.

Montaj açıklamaları

- Montaj işleminden önce ürün nakliye hasarları yönünden kontrol edilmelidir. Montaj işleminden sonra nakliye veya yüzey hasarları için sorumluluk üstlenilmemektedir.
- Boruların ve armatürün montajı, yıkanması ve kontrolü geçerli normlara göre yapılmalıdır.
- Ülkelerde geçerli kurulum yönetmeliklerine riayet edilmelidir.

Instrucțiuni de montare

- Înainte de instalare verificați, dacă produsul prezintă deteriorări de transport. După instalare garanția nu acoperă deteriorările de transport și cele de suprafață.
- Conductele și bateriile trebuie montate, spălate și verificate conform normelor în vigoare.
- Respectați reglementările referitoare la instalare valabile în țara respectivă.

Simge açıklaması



Asetik asit içeren silikon kullanmayın!

Descrierea simbolurilor



Nu utilizați silicon cu conținut de acid acetic!



Ölçüleri (Bakınız sayfa 19)



Dimensiuni (vezi pag. 19)



Yedek Parçalar (Bakınız sayfa 17)



Piese de schimb (vezi pag. 17)



Temizleme

birlikte verilen broşür



Curățare

vezi broşura alăturată.



Ayarlama

Sıcak su sınırlayıcı özelliğine sahip tek kollu bataryanın ayarlanması için 24. sayfaya bakınız. Bir sürekli akışlı su ısıtıcısı ile birlikte kullanılırsa sıcak su sınırlayıcısı önerilmez.



Reglare

Baterie monocomadă cu limitarea apei calde, pentru reglare vezi pag. 24. Dacă conectați bateria la un boiler instant nu vă recomandăm instalarea unui opritor de apă caldă.

Montajı Bakınız sayfa 20



Montare vezi pag. 20



Υπ δείξεις σφ λεί ς

- ⚠ Για να αποφύγετε τραυματισμούς κατά τη συναρμολόγηση πρέπει να φοράτε γάντια.



Varnostna opozorila

- ⚠ Lors du montage, porter des gants de protection pour éviter toute blessure par écrasement ou coupure.

Οδηγίες σ ν ρμ λόγησης

- Πριν τη συναρμολόγηση πρέπει να εξεταστεί το προϊόν για ζημιές μεταφοράς. Μετά την εγκατάσταση δεν αναγνωρίζονται ζημιές από τη μεταφορά ή επιφανειακές ζημιές.
- Οι σωλήνες και η μπαταρία πρέπει να τοποθετηθούν σύμφωνα με τα ισχύοντα πρότυπα, να τεθούν υπό πίεση και να δοκιμαστούν.
- Θα πρέπει να τηρούνται οι οδηγίες εγκατάστασης που ισχύουν σε κάθε κράτος.

Navodila za montažo

- Pred montažo je treba izdelek preveriti glede morebitnih transportnih poškodb. Po vgradnji transportne ali površinske poškodbe ne bodo več priznane.
- Cevi in armaturo je treba montirati, izprati in preveriti po veljavnih standardih.
- Upravljanje je treba pravilnike o inštalacijah, ki veljajo v posamezni državi.

Περιγραφή σ μβόλων



Μην χρησιμοποιείτε σιλικόνη που περιέχει οξικό οξύ!



Δι στάσεις (βλ. σελίδα 19)



Αντ λλ κτικά (βλ. σελίδα 17)



Κ θ ρισμός

βλ. συνημμένο φυλλάδιο



Ρύθμιση

Για να προσαρμόσετε το δοσομετρητή ζεστού νερού σε αναμεικτικές μπαταρίες, παρακαλούμε δείτε τη ρύθμιση στη σελ. 24. Δεν συνιστάται η διάταξη φραγής ζεστού νερού σε συνδυασμό με ταχυθερμοσίφωνα.

Opis simbola



Ne smete uporabiti silikona, ki vsebuje očetno kislino!



Mere (glejte stran 19)



Rezervni deli (glejte stran 17)



Čiščenje

glejte priloženi brošuri.



Justiranje

Enoročne mešalne baterije z omejevalnikom tople vode, za justiranje glejte stran 24. V povezavi s pretočnimi grelniki zapora tople vode ni priporočljiva.

Σ ν ρμ λόγηση βλ. σελίδ 20



Montaža Glejte stran 20.



Ohutusjuhised

- ⚠ Kandke paigaldamisel muljumis- ja löikevigastuste vältimiseks kindaid.

Paigaldamisjuhised

- Enne paigaldamist tuleb toodet kontrollida transpordikahjustuste osas Pärast paigaldamist ei tunnustata enam transpordi- või pinnakahjustuste kaebuseid.
- Voolikute ja segisti paigaldamisel, loputamisel ja kontrollimisel tuleb lähtuda kehtivatest normatiividest
- Vastavas riigis kehtivaid paigalduseeskirju tuleb järgida.

Sümbolite kirjeldus



Ärge kasutage äädikhapet sisaldavat silikooni!



Mõõtude (vt lk 19)



Varuosad (vt lk 17)



Puhastamine

vt kaasasolevast brošüürist.



Reguleerimine

Ühe juhtkangiga segisti kuuma vee piiraja reguleerimise kohta vt lk 24. Läbivoolu boilerite puhul pole reguleerimine soovitatav.

Drošības norādes

- ⚠ Montāžas laikā, lai izvairītos no saspiedumiem un iegriezumiem, nepieciešams nēsāt cimdus.

Norādījumi montāžai

- Pirms montāžas nepieciešams pārbaudīt, vai produktam transportēšanas laikā nav radušies bojājumi. Pēc iebūvēšanas bojājumi, kas radušies transportēšanas laikā, vai virsmas bojājumi netiek atzīti.
- Cauruļvadi un armatūra ir jāuzstāda, jāizskalo un jāpārbauda saskaņā ar spēkā esošajiem standartiem.
- Jāievēro attiecīgās valstīs spēkā esošās montāžas prasības.

Simbolu nozīme



Neizmantoj silikonu, kas satur etiķskābi!



Izmērus (skat. 19. lpp.)



Rezerves daļas (skat. 17. lpp.)



Tīrīšana

skatiet pievienotajā brošūrā.



Ieregulēšana

Viensvires jaucējkrāns ar siltā ūdens ierobežošanu, ieregulēšanu skat. 24. lpp. Kombinācijā ar caurteces sildītāju karstā ūdens ierobežošana nav ieteicama.

Paigaldamine vt lk 20



Montāža skat. 20. lpp.



Sigurnosne napomene

- ⚠ Prilikom montaže se radi sprečavanja prignječenja i posekotina moraju nositi rukavice.



Sikkerhetshenvisninger

- ⚠ Bruk hansker under montasjen for å unngå klem- og kuttskader.

Instrukcije za montažu

- Pre montaže se mora proveriti da li je proizvod oštećen pri transportu. Nakon ugradnje se ne priznaju nikakve reklamacije koje se odnose na površinska i transportna oštećenja.
- Vodovi i armatura moraju biti postavljeni, isprani i testirani prema važećim normama.
- Treba se pridržavati propisa koji u određenim zemljama važe za instalacije.

Montagehenvisninger

- Før montasjen skal produktet sjekkes for transportskader. Etter monteringen aksepteres ikke noen transport eller overflateskader.
- Ledningene og armaturen skal monteres, spyles og sjekkes iht. de gyldige normer.
- Gjeldende retningslinjer for rørleggerarbeid i de enkelte land skal følges.

Opis simbola



Nemojte koristiti silikon koji sadrži sirćetnu kiselinu!



Mere (vidi stranu 19)



Rezervni delovi (vidi stranu 17)



Čišćenje

vidi priloženoj brošuri.



Podešavanje

Za podešavanje jednoručnih mešača sa ograničivačem tople vode vidi str. 24. U kombinaciji sa protočnim bojlerima ne preporučuje se primena sistema za blokiranje dotoka tople vode.

Symbolbeskrivelse



Ikke bruk silikon som inneholder eddiksyre!



Mål (se side 19)



Service deler (se side 17)



Rengjøring

se vedlagt brosjyre.



Justering

Enhåndblande batteri med varmtvannsbegrensning. For justering se side 24. I forbindelse med en gjennomstrømningssovn er det ikke anbefalt med varmtvannsbegrensning.

Montaža vidi stranu 20



Montasje se side 20



Ук з ния з безоп сност

- ⚠ При монтажа трябва да се носят ръкавици, за да се избегнат наранявания поради притискане или порязване.

Ук з ния з монт ж

- Преди монтажа продуктът трябва да се провери за транспортни щети. След монтажа не се признават транспортни или повърхностни щети.
- Тръбопроводите и арматурата трябва да се монтират, промият и проверят в съответствие с валидните норми.
- Трябва да бъдат спазвани валидните в съответните страни предписания за инсталиране.

Опис ние н символите



Не използвайте силикон, съдържащ оцетна киселина!



Р змери (вижте стр. 19)



Сервизни ч сти (вижте стр. 17)



Почиств не

от приложената брошура.



Юстир не

Смесител с една ръкохватка с ограничител за топлата вода, юстирането вижте на стр. 24. Във връзка с проточни нагреватели не се препоръчва блокировка за топлата вода.

Udhëzime sigurie

- ⚠ Për të evituar lëndimet e pickimeve ose të prerjeve gjatë procesit të montimit duhet që të vishni doreza.

Udhëzime për montimin

Përpara montimit duhet që produkti të kontrollohet për dëmtime nga transporti. Pas instalimit nuk do të njihet asnjë dëmtim nga transporti ose dëmtim i sipërfaqes. Tubacionet dhe rubinetet duhet që të montohen, të shpëlahen dhe të kontrollohen sipas standardeve në fuqi. Duhet të respektohen linjat udhëzuese të instalimit, të vlefshme për vendet respektive.

Përshkrimi i simbolit



Mos përdorni silikon që në përbërje ka acid acetik.



Përmasat (shih faqen 19)



Pjesë ndërrimi (shih faqen 17)



Pastrimi

shikoni broshurën bashkëngjitur.



Justimi

Rubinet me ujë të pëzier me kufizim të ujit të ngrohtë, justimi shih faqen 24. Në kombinim me ngrohësit elektrikë të ujit nuk rekomandohet bllokada e ujit të ngrohtë.

Монт ж вижте стр. 20



Montimi shih faqen 20

⚠️ تنبيهات الأمان

⚠️ يجب إرتداء قفازات اليد أثناء التركيب لتجنب حدوث أخطار الإنحشار أو الجروح.

تعليمات التركيب

- قبل القيام بعملية التركيب، يجب فحص المنتج للتأكد من خلوه من أية تلفيات ناتجة عن النقل. بعد القيام بعملية التركيب، لن يتم الاعتراف بوجود أية تلفيات سطحية أو تلفيات ناتجة عن عملية النقل.
- يجب تركيب وغسيل واختبار التوصيلات وخلطات المياه طبقاً للمعايير السارية.
- يجب مراعاة القواعد الخاصة بالتركيب وأعمال السباكة وفق اللوائح الخاصة بك

وصف الرمز

هام! لا تستخدم السليكون الذي يحتوي على أحماض!



أبعاد (راجع صفحة 20)



تنبيهات الأمان (راجع صفحة 17)



التنظيف (راجع صفحة 26)



الضبط



لضبط محدد الماء الساخن في الخلاطات ذات المقبض الواحد، يرجى الرجوع إلى صفحة 25. ولا ينصح إجراء أي ضبط عند استخدام سخان مياه ذي تدفق مستمر.

XXX = Farbcodierung / Couleurs / Colors / Trattamento/ Acabados / Kleuren / Overflade / Acabamentos / kody wykończenia powierzchni / kód povrchové úpravy / kód povrchovej úpravy/ 顔色代码 / Код цвета поверхности / Színkódok / Värikoodi / Färgkodning / Spalva/ Boje/ Renkler / cod de culori / Χρώματα / Barve / Värvikood / Krāsas / Oznake boja/ Fargekode/ Цветово кодиране / Kodimi i ngjyrave/ الألوان

000 = chrom / chromé / chrome plated / cromato / cromado / verchromd / Krom / cromado / chrom / chrom / chróm / 镀铬 / хром / króm/ kromi / krom / chrom / krom / krom / crom / Επιχρωμιωμένο / krom / kroom / hroma / hrom/ krom / хром / krom / كروم

400 = weiß/chrom / blanc/chromé / white/chrome plated / bianco/cromato / blanco/cromado / wit/verchromd / Hvid/Krom / branco/cromado / biaty/chrom / bílá/chrom / biela/chróm / 白色/镀铬 / белый/хром / fehér/króm / valkoinen/kromi / vit/krom / balta/chrom / bijela/krom / beyaz/Krom / alb/crom / λευκό/ Επιχρωμιωμένο / bela/krom / valge/kroom / balta/hroma / bela/hrom / hvit/krom / бял/ хром / e bardhë/krom / أبيض/كروم

800 = edelstahl-optik / aspect acier inox / stainless steel optic / acciaio inox acciaio / acero especial / RVS-look / Stainless steel optic / aço imaculado ótica / stal szlachetna / nerezová ocel / ušľachtilá oceľ / 不锈钢表面 / сталь / acéloptika / inox-optinen / rostfri-optik / plienas/ plemeniti čelik / paslanmaz çelik - optik/ otel inox / οπτική ανοξείδωτου χάλυβα / videz legiranega jekla / roostevaba optik / tērauda / dezen plemeniti čelik / rustfritt stål optikk / оптика на благородна стомана / optikë çeliku/ مظهر الإستيليس ستيل

التركيب راجع صفحة 20



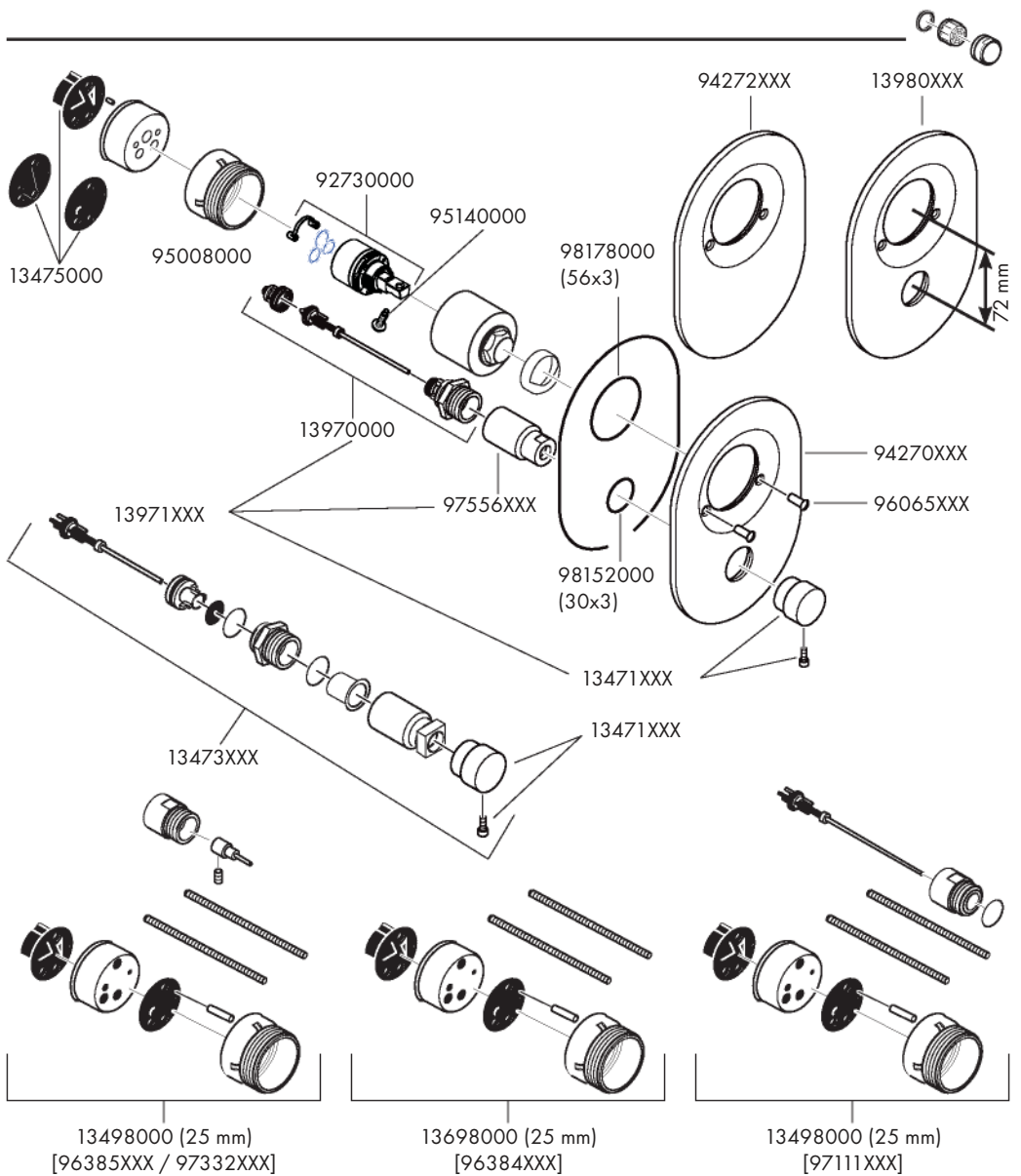



| | | 96384XXX | 96385XXX | 97111XXX | 97332XXX |
|-----------------------|----------|-----------------|-----------------|-----------------|-----------------|
| Avista | 31792000 | x | x | x | x |
| Ecos (Planis) | 95518XXX | x | x | x | x |
| Focus E | 31791000 | x | x | x | x |
| Focus E ² | 98532000 | x | x | x | x |
| Focus S | 31793000 | x | x | x | x |
| Mediano | 95865000 | x | x | x | x |
| Metris | 95519000 | x | x | x | x |
| Metris Classic | 31294000 | x | x | x | x |
| Metris E | 31094000 | x | x | x | x |
| Metris Puro | 95618000 | x | x | x | x |
| Metris S | 31093000 | x | x | x | x |
| Metropol E | 14094000 | x | x | x | x |
| Metropol S | 14895000 | x | x | x | x |
| PuraVida | 95273XXX | x | x | x | x |
| Sportive ² | 14897000 | x | x | x | x |
| Status ² | 95673000 | x | x | x | x |
| Talis Classic | 14193000 | x | x | x | x |
| Talis E ² | 31692000 | x | x | x | x |
| Talis Puro | 95656000 | x | x | x | x |
| Talis S | 32092000 | x | x | x | x |
| Talis S ² | 32092000 | x | x | x | x |
| Bouroullec | 95720000 | - | - | - | - |
| Carlton | 17092XXX | x | x | x | x |
| Citterio | 39491000 | x | x | x | x |
| Citterio M | 34096000 | x | x | x | x |
| Massaud | 38090000 | x | x | x | x |
| Starck | 10492000 | x | x | x | x |
| Starck | 10490000 | x | - | - | - |
| Starck Organic | 98311000 | - | - | - | - |
| Starck X | 10490000 | x | - | - | - |
| Steel | 35093800 | x | - | - | - |
| Uno ² | 98553000 | x | - | - | - |
| Urquiola | 11493000 | x | - | - | - |



31792000



95518XXX



31791000



98532000



31793000



95865000



95519000



31294000



31094000



95618000



31093000



14094000



14895000



95273XXX



14897000



95673000



14193000



95656000



31692000



32092000



95720000



17092XXX



39491000



34096000



38090000



10492000



10490000



98311000



35093800



98553000



11493000

96384XXX

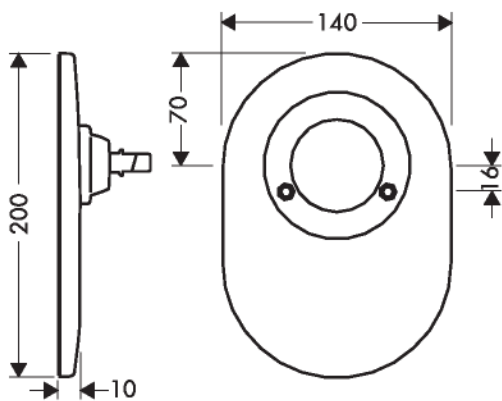

96385XXX / 97111XXX

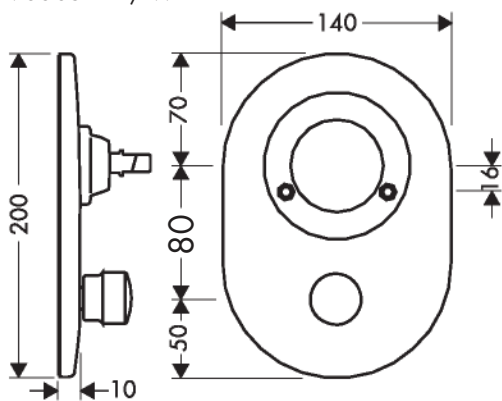

97332XXX

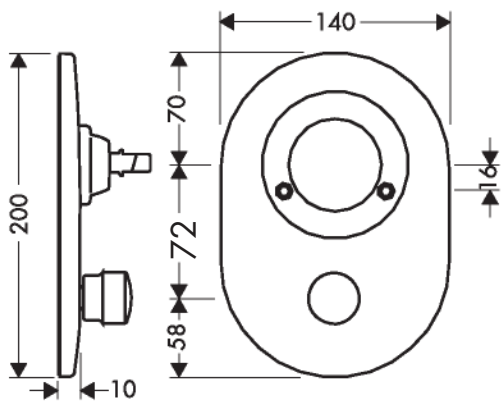

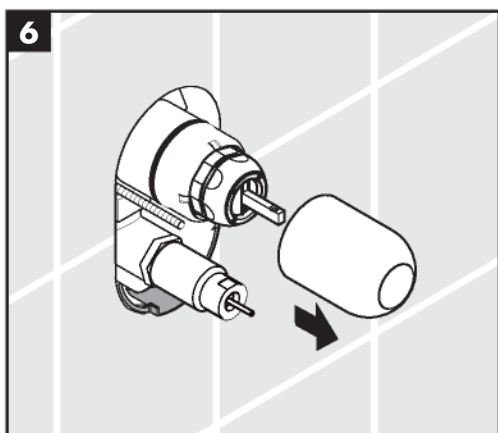
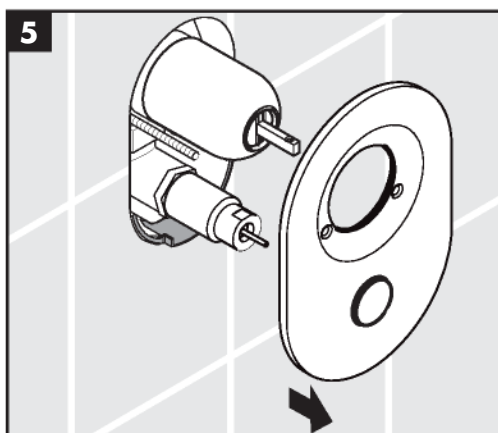
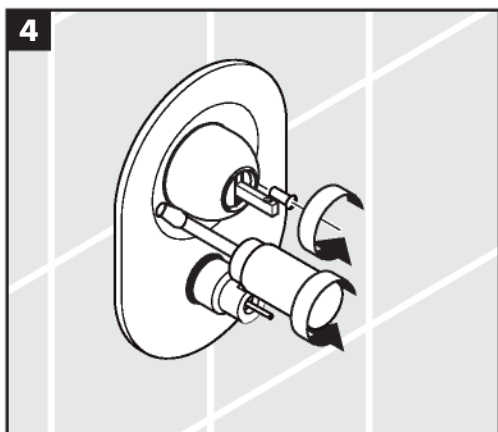
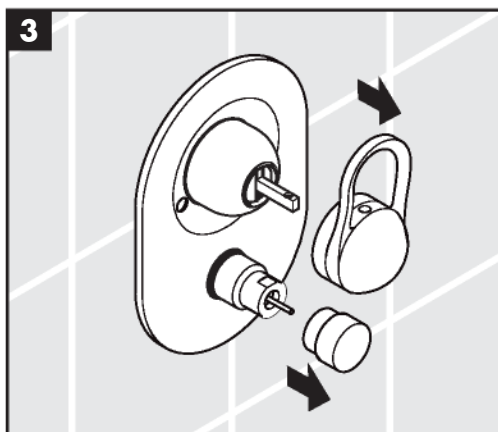
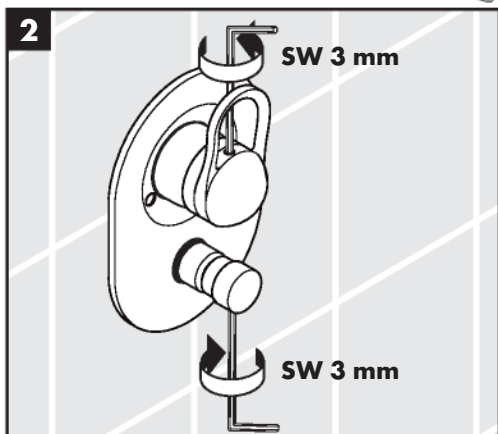
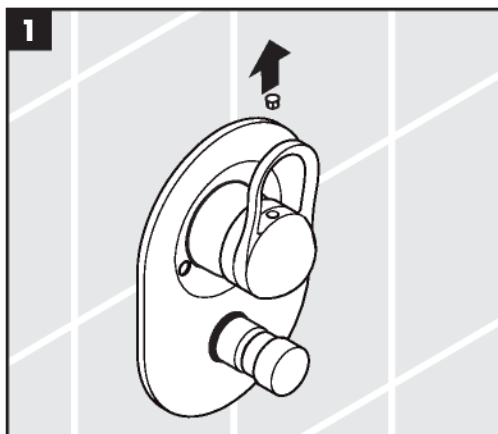

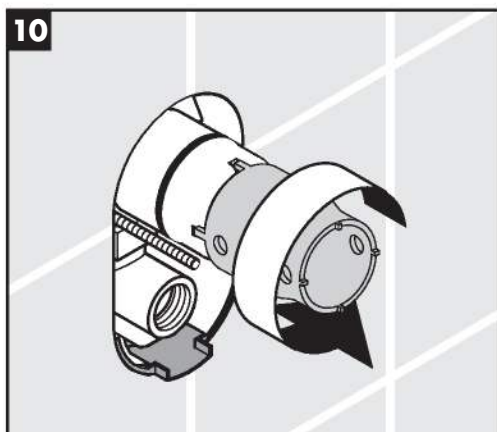
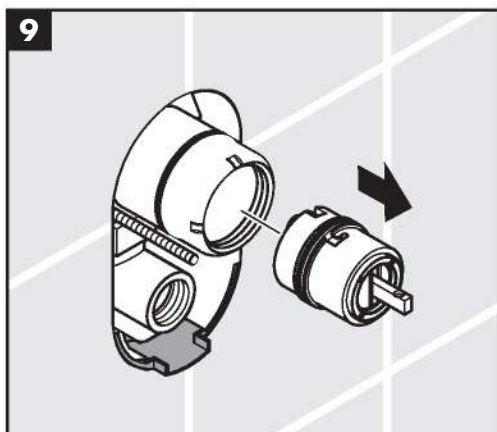
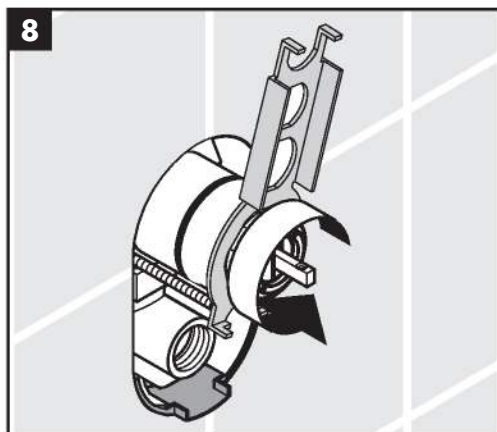
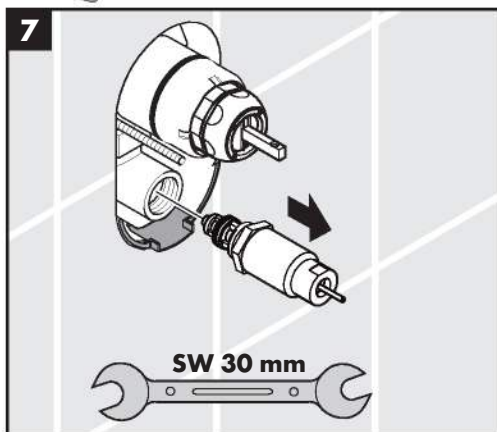

11

<5/87

>6/87

Verlängerung
jeu de rallonge
extension
prolunga
Prolongación
Verlengstuk
Forlængersæt
Crescente
Przedłużka
prodložení
Predĺženie
加长件
Удлинение
Hosszabbitás
Pidennys
Förlängning
Ilgiklis
Produljenje

Uzatma
Prelungitor
Σωλήνας επιμήκυνσης
Podaljšek
Pikendus
Pagarinājums
Produžetak
Forlængelse
Удължител
Zgajātēs
وصلة إطالة

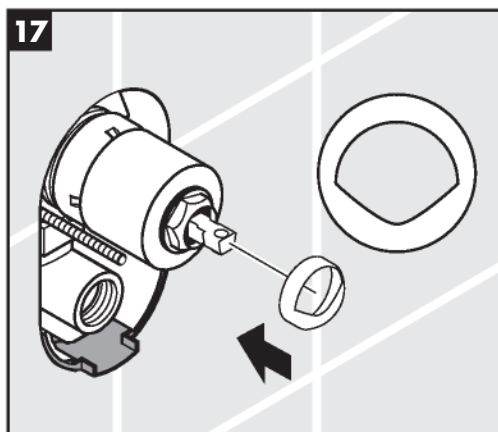
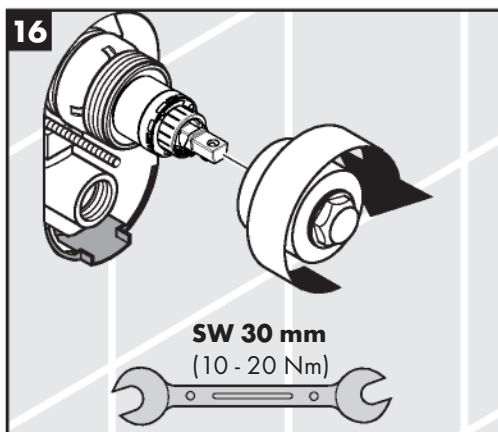
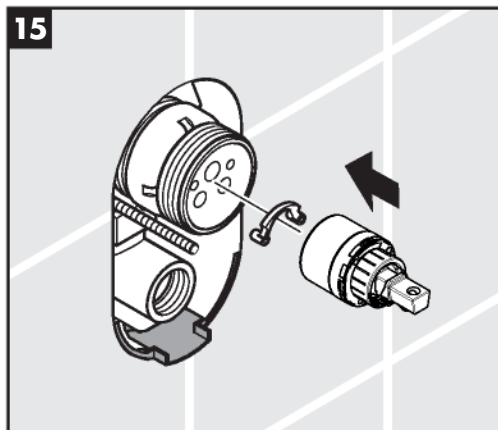
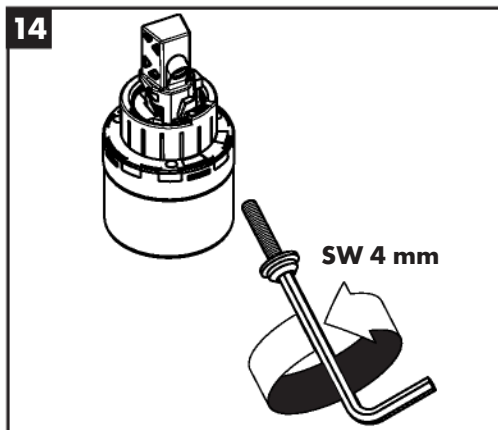
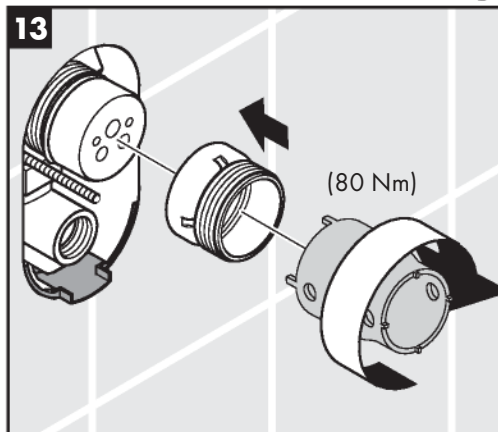
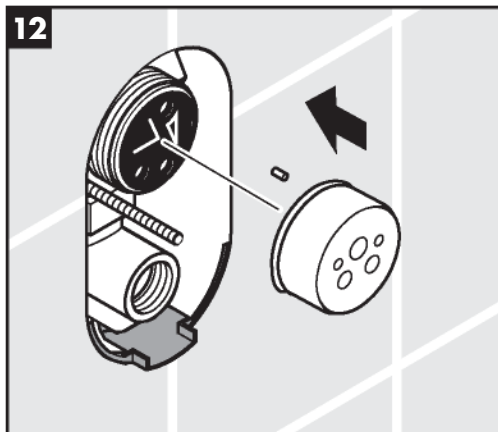



18

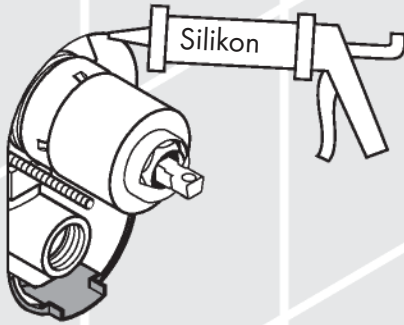

19

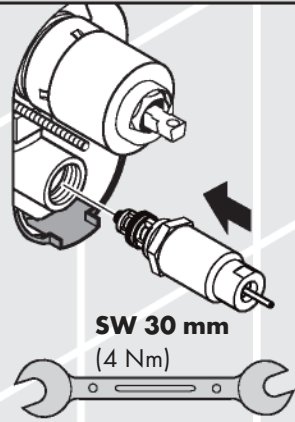

20

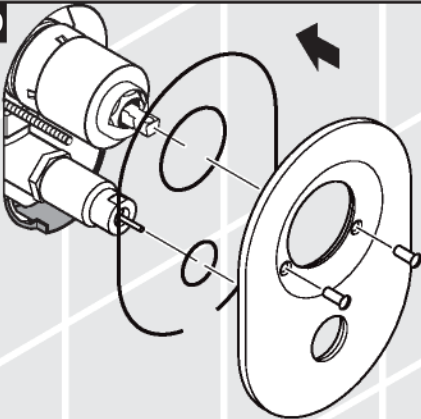

21

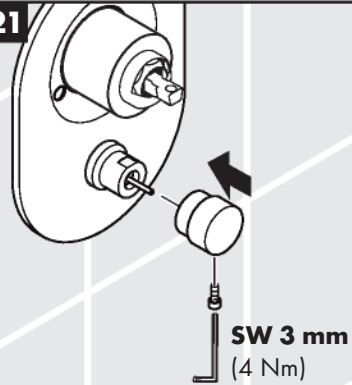

22

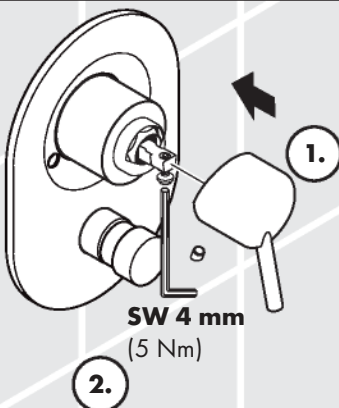



0,3 MPa
0,3 МП
0,3 میجاباسکال

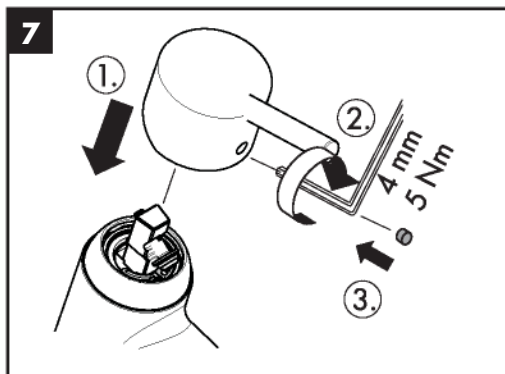
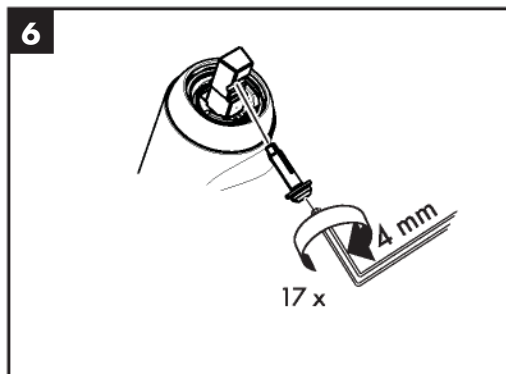
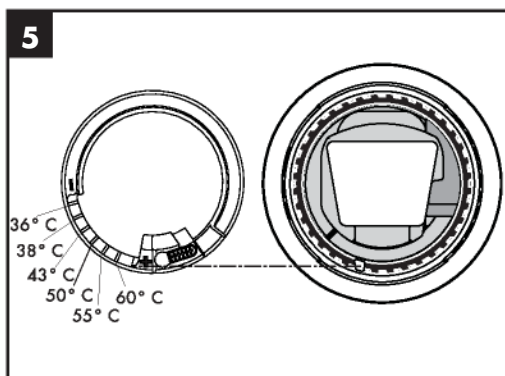
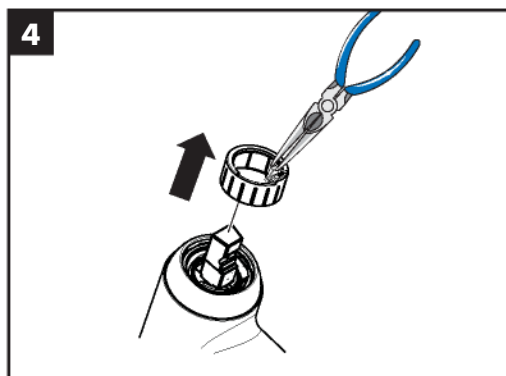
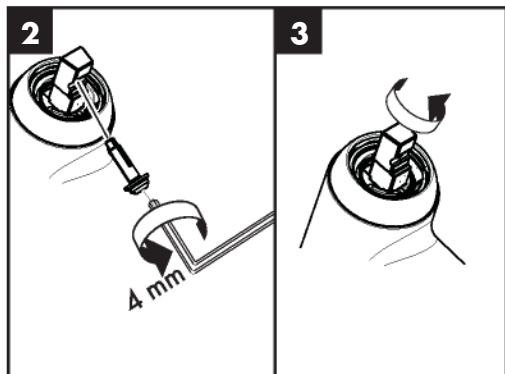
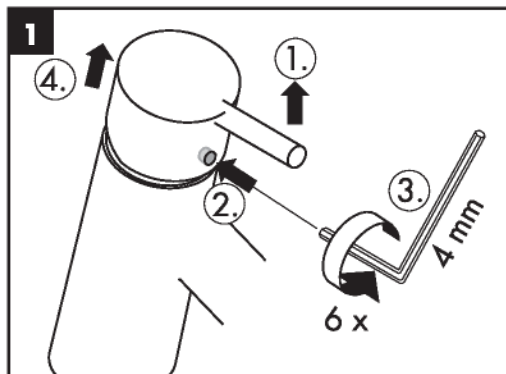



- DE** Reinigungsempfehlung / Garantie / Kontakt
FR Recommandation pour le nettoyage / Garanties / Contact
EN Cleaning recommendation / Warranty / Contact
IT Raccomandazione di pulizia / Garanzia / Contatto
ES Recomendaciones para la limpieza / Garantía / Contacto
NL Aanbevelingen inzake reiniging / Garantie / Contact
DK Rensning, anbefaling / Garanti / Kontakt
PT Recomendações de limpeza / Garantia / Contacto
PL Zalecenie dotyczące pielęgnacji / Gwarancja / Kontakt
CS Doporučení k čištění / Záruka / Kontakt
SK Odporúčania pre čistenie / Záruka / Kontakt
ZH 清洁指南 / 担保 / 接触
RU Рекомендации по очистке / Гарантия / Контакты
HU Tisztítási tanácsok / Garancia / érintkezés
FI Puhdistussuositus / Takuu / Kosketus
SV Rengöringsrekommendationer / Garanti / Contacto
LT Valymo rekomendacijos / Garantija / Kontaktai
HR Preporuke za čišćenje / Garancija / Kontakt
TR Temizleme önerisi / Garanti / Temas
RO Recomandări pentru curățare / Garanție / Contact
EL Σύσταση καθαρισμού / Εγγύηση / επαφή
SL Priporočilo za čiščenje / Garancija / Kontakt
ET Puhastussoovitused / Garantii / Kontakt
LV Tīrīšanas ieteikumi / Garantija / Kontakti
SR Preporuke za čišćenje / Garancija / Kontakt
NO Anbefaling for rengjøring / Garanti / Kontakt
BG Препоръка за почистване / Гаранция / Контакт
SQ Këshilla rreth pastrimit / Garancia / Kontakt
KO 세정시 권장사항 / 품질보증 / 접촉
AR توصيات التنظيف / الضمان (الولايات المتحدة الأمريكية) / اتصال



[www.hansgrohe.com/
cleaning-recommendation](http://www.hansgrohe.com/cleaning-recommendation)



[www.hansgrohe.com/
cleaning-recommendation](http://www.hansgrohe.com/cleaning-recommendation)



[www.hansgrohe.com/
cleaning-recommendation](http://www.hansgrohe.com/cleaning-recommendation)



[www.hansgrohe.com/
cleaning-recommendation](http://www.hansgrohe.com/cleaning-recommendation)

